

ACCESSIBILITY IN PUBLIC & COMMERCIAL BUILDINGS

Aritco PublicLift Access
Product catalogue
2021





**Aritco public &
commercial lifts
- accessibility lifts for
all needs.**

Our journey started 25 years ago, with the simple idea of improving mobility everywhere. Today, Aritco lifts can be found in over 35,000 buildings and private homes around the world.

Simplicity, quality and innovation are the hallmarks of all Aritco's activities. We are constantly seeking new ways to improve the quality, design and user-friendliness of our

products, as well as our environmental impact. Safety and reliability are top priorities, and we follow Europe's strictest quality and safety standards.

All Aritco lifts are developed and produced in Stockholm, Sweden, and we are proud to maintain the highest level of quality in all stages of the process, from design through to final installation.



ARITCO™



This catalogue is primarily made for all our partners around the world. The purpose is to show what Aritco can offer in terms of products, options and possible combinations.

Due to continuous product development, all specifications included in this catalogue are subject to change without prior notice. Reservations are made regarding misprints and articles being out of stock.

CONTENT

Product summary	4
Lift sizes	6
Lift color	10
Carrier	12
Floor	13
Control panel.....	14
Doors.....	16
Door control	20
Door machinery	22
Door options	23
Lift walls.....	24
Lift wall options	25
Communication.....	26
Drive system.....	27
Outdoor version	28
Aritco PublicLift Access Goods version.....	30
Fixing the lift	32
European standards and safety.....	33
Recommended sales arguments.....	34
Drawings	36

PRODUCT SUMMARY

Aritco PublicLift Access is designed to make public and commercial buildings accessible for everyone. The lift expresses Scandinavian design and features a backlit panel and lit handrail.

Type of lift :	Platform lift intended for use in public & commercial environment.
Technical compliance:	European Machine directive 2006/42/EC European standard EN 81-41
Drive system:	Patented screw/nut system
Rated speed (max):	Max 0,15m/s Max 0,25m/s ¹⁾
Travel height:	250 -13 000 mm ²⁾
Number of stops:	Max. 6 stops per lift
Number of doors:	Max. 6 doors per lift
Number of doors per floor:	Max. 2 doors per floor
Pit:	50 mm (no pit is required when there is a ramp)
Entry:	One, two or three sides
Top height:	Minimum 2240 mm. Maximum 4000 mm. (1100-1600 mm with half height door)
Platform control:	"Hold to run", the destination button must be kept pressed down during the whole ride ³⁾
Landing control (on door):	One-touch call
Environment:	Indoor/outdoor
Emergency lowering:	Battery operated emergency lowering
Control voltage:	24V
Motor:	2,2kW (3kW for higher speed)
Locking system:	Electrical
Power supply:	1-phase 230V 50 Hz/16 A/16 A slow 3-phase 230V 50 Hz/9 A/16 A slow 3-phase 400V 50 Hz/5.2 A/16 A slow
Rated load:	250, 410 or 500 kg (depending on platform size)

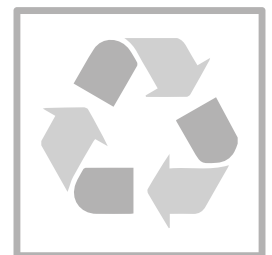
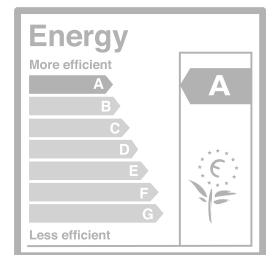

- 1) For installations outside Europe: As option for lifts with 400 V 3-phase.
- 2) Travel height when having a half door is maximum 3000 mm (inside Europe)
- 3) For installations outside Europe one-touch operation is available.

Aritco PublicLift Access



Lift walls
page 24

Lift color
page 10

Doors
page 16

Carrier
page 12

LIFT SIZE

900 x 1040

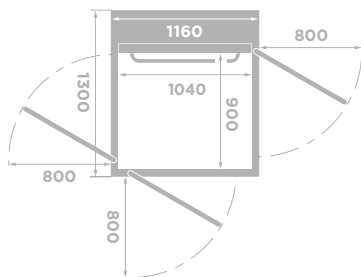
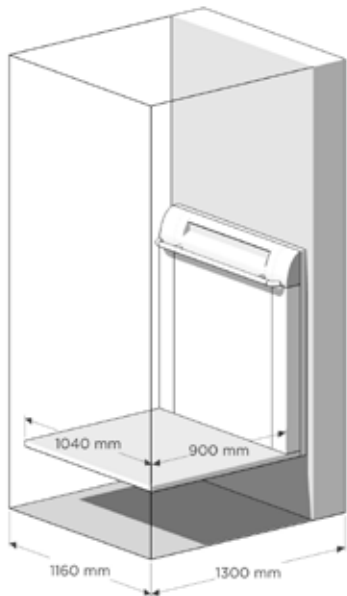

Carrier size: 900 x 1040
External dim.: 1300 x 1160
Rated load: 250 kg / 2 persons
Wheelchair: -

900 x 1280

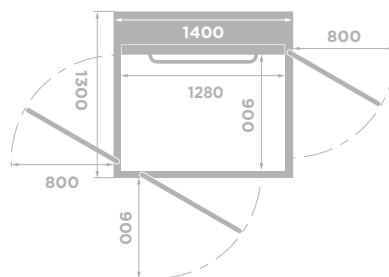
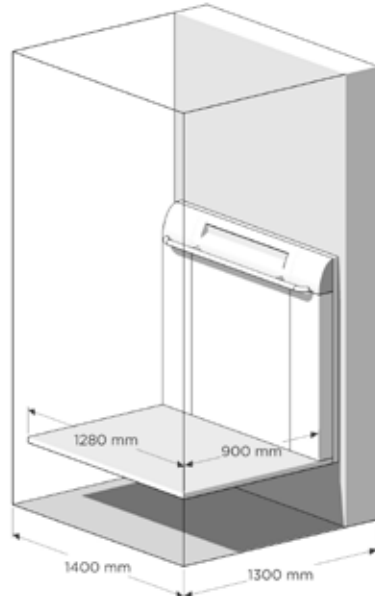

Carrier size: 900 x 1280
External dim.: 1300 x 1400
Rated load: 410 kg / 5 persons
Wheelchair: Lone user or type A*

900 x 1480

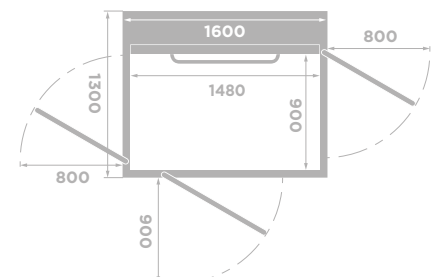
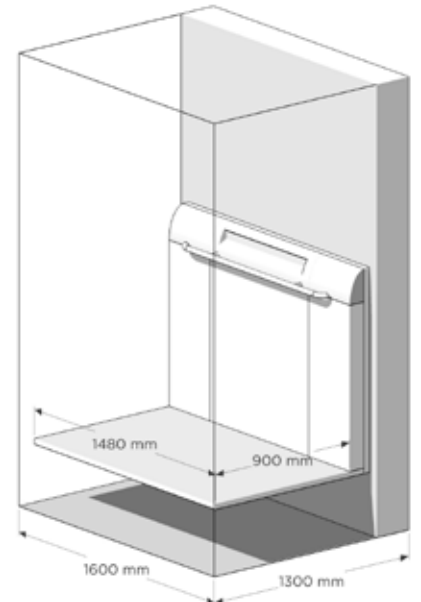

Carrier size: 900 x 1480
External dim.: 1300 x 1600
Rated load: 410, 500 kg / 5, 6 persons
Wheelchair: A or B with attendant*

(mm)

Aritco PublicLift Access is available in 8 different platform sizes. The rated load depends on the platform size.

Carrier size: Inner dimensions of the lift
External dimensions: Outer dimensions of the lift (shaft size).

For detailed drawings see page 36.

1000 x 1280

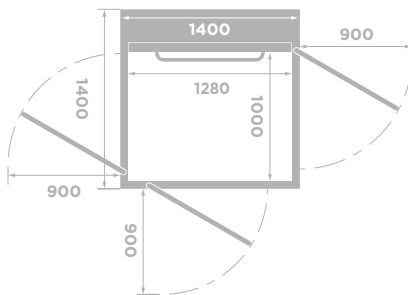
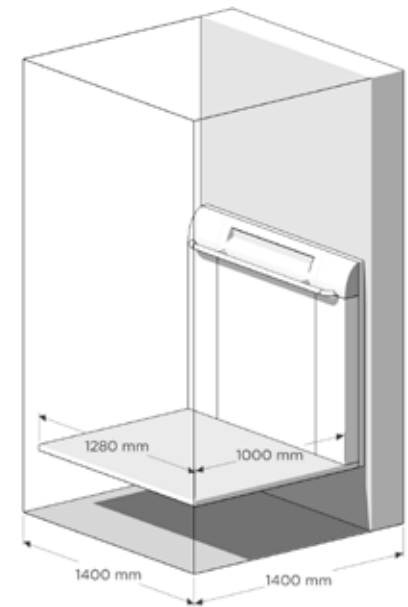

Carrier size: 1000 x 1280
External dim.: 1400 x 1400
Rated load: 410 kg / 5 persons
Wheelchair: Lone user or type A*

1000 x 1480

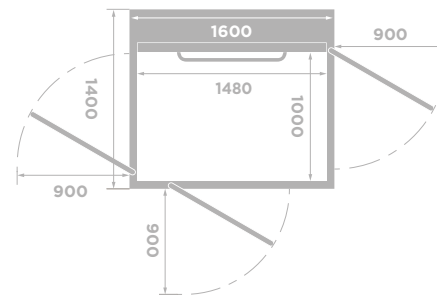
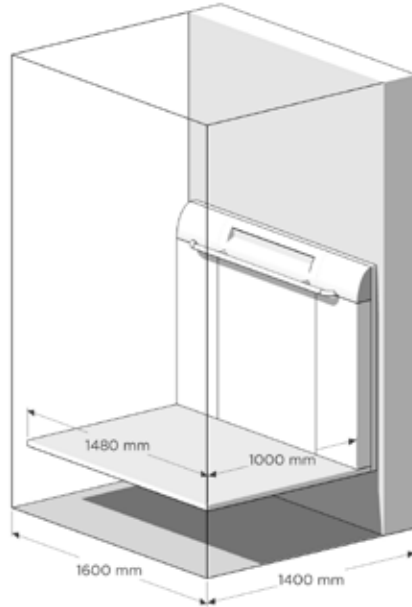

Carrier size: 1000 x 1480
External dim.: 1400 x 1600
Rated load: 410, 500 kg / 5, 6 persons
Wheelchair: A or B with attendant*

1100 x 1480

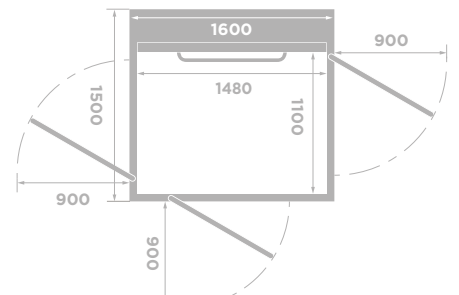
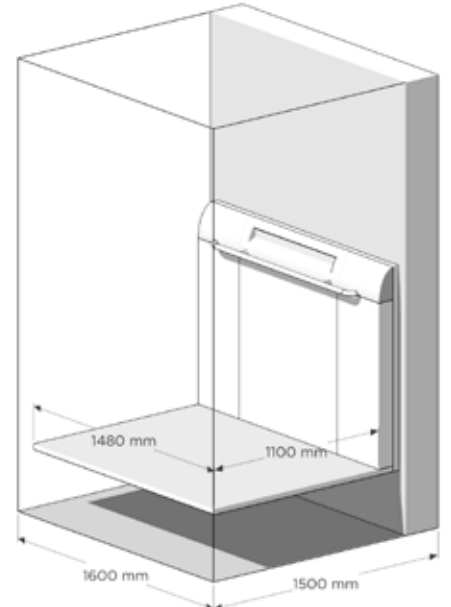

Carrier size: 1100 x 1480
External dim.: 1500 x 1600
Rated load: 410, 500 kg / 5, 6 persons
Wheelchair: A or B with attendant, adjacent entry*

(mm)

Load limits per power supply	400V 3-phase 50Hz	400V 3-phase 60Hz	230V 3-phase 50Hz	230V 3-phase 60Hz	230V 1-phase 50/60Hz
250 kg	•	•	•	•	•
410 kg	•	•	•	•	•
500 kg	•		•		

LIFT SIZES

1100 x 1580

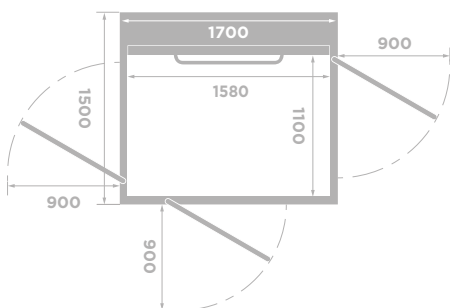
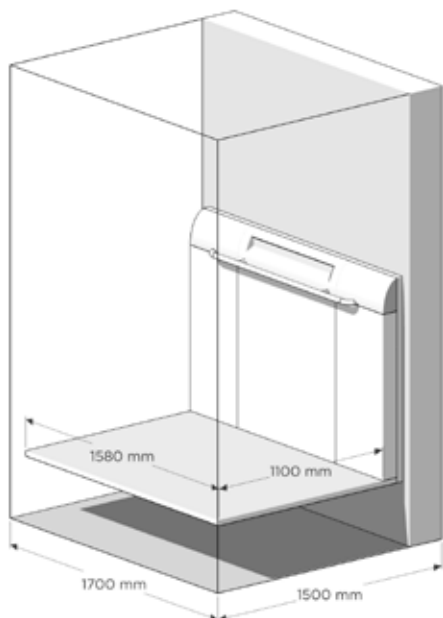

Carrier size: 1100 x 1580
External dim.: 1500 x 1700
Rated load: 500 kg / 6 persons
Wheelchair: A or B with attendant, adjacent entry*

1000 x 1980

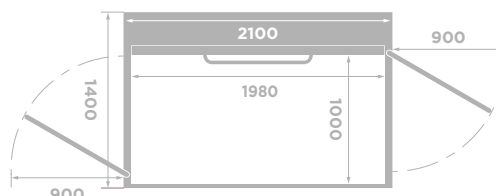
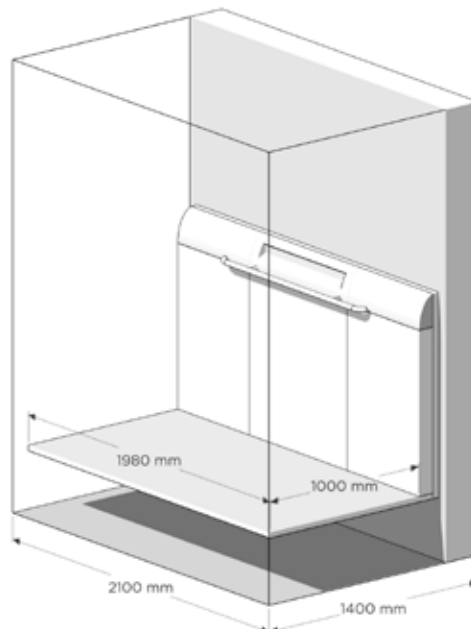

Carrier size: 1000 x 1980
External dim.: 1400 x 2100
Rated load: 500 kg / 6 persons
Wheelchair: A or B with attendant*

(mm)

* Aritco PublicLift Access follows the requirements stated for lifts regarding the possibility to fit a wheelchair with or without attendant. National guidelines may apply.

Depending on the size of the platform you can fit either a wheelchair or a wheelchair with an attendant.

Type A and B wheelchairs are defined in :

- EN 12183 Manual wheelchairs - requirements and test methods
- EN 12184 Electrically powered wheelchairs, scooters and their charges - Requirements and test methods

Dimensions of wheelchair	Class A	Class B
Total length	1200	1400
Total width	700	700

EN81-41 and EN81-70 defines the sizes of the platform and what type of wheelchair it is intended for.

LIFT COLOR

Aritco PublicLift Access can be painted in any RAL color from the Chart K7 classic chart (except for pearl and fluoridating colors*).

Aritco PublicLift Access is painted in Traffic White, RAL 9016, as standard. The paint is a soft-textured powder coat with a matt surface (gloss level 12).

Door handles and handrail are painted in colors that shall protect them from wear and tear. The white color is RAL 9016, with gloss level 70 and

without texture. The grey color looks like aluminum and is the anodic color Natura with gloss level 20 and without texture.

The entire lift can be ordered in another color as an option. It is also possible to order only the doors or walls in a different color. When another color is chosen for the doors, all the doors will be supplied in the same color.

Common colors, see page 11, have shorter lead time and lower price. The rest of the colors from RAL chart K7 classic have longer lead time and higher price.



Standard:

The whole lift painted in standard color RAL 9016 (Traffic white). Door handles in grey as standard, can be ordered in RAL 9016 (Traffic white) as option. Handrail in RAL 9016 (Traffic white).

Full color option:

The whole lift painted in optional color (Incl. shaft, doors and the panels around and under the control panel.) Door handles in grey. Handrail in grey.

Lift partially painted in different colors:

- Lift walls/Shaft in one color
- All door blades in one color
- All door frames in one color
- Panels around and under the control panel in one color
- One of the above choices or a combination of them

Door handles in grey as standard, can be ordered in RAL 9016 (Traffic white) as option for lift with door blades in RAL 9016 (Traffic white). Handrail in RAL 9016 (Traffic white) as standard, if platform is painted in another color the handrail is grey.



Traffic white - Standard color
RAL 9016

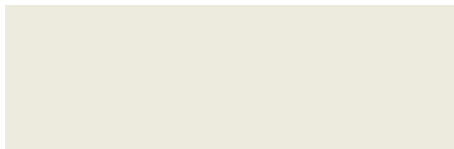

Grey white
RAL 9002



White aluminum
RAL 9006



Telegrey 1
RAL 7045



Anthracite grey
RAL 7016



Jet black
RAL 9005

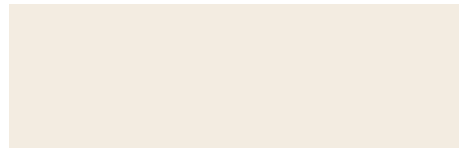

Pure white
RAL 9010

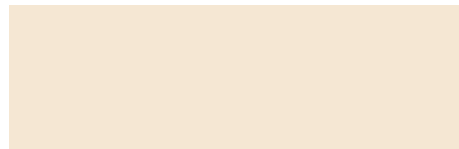

Oyster white
RAL 1013



Light ivory
RAL 1015



Moss green
RAL 6005



Brown red
RAL 3011

Note that the actual color of the lift may differ from the color samples pictured above.

* Any RAL color means in this case any RAL color from the 213 color RAL chart K7 classic except the following colors that are not available;
Fluoridating colors: RAL 1026, 2005, 2007, 3024, 3026, 6038
Pearl Colors: RAL 1035, 1036, 2013, 3032, 3033, 4011, 4012, 5025, 5026, 6035, 6036, 7048, 8029, 9022, 9023

CARRIER

The platform is in its basic execution delivered with a side wall (half height) including the control panel.

Used for lifts with an open shaft, half height doors or when cost must be kept down. Height 1100 mm. Panels around and under the control panel are painted in RAL 9016 (Traffic white) as standard, but can be painted in any RAL color as an option.

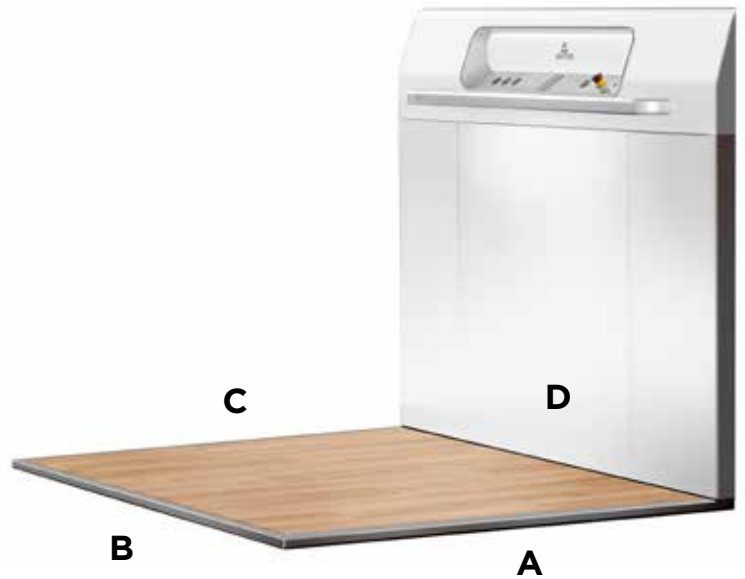

A,B,C and D-side of platform.



FULL HEIGHT WALL

To get a conventional lift feeling the Aritco PublicLift Access can be delivered with a full height wall (2100 mm high) as an option. The full height wall has a big mirror that goes along the whole machine side. The mirror has an integrated LED light. Included as standard for full height wall. Panels around and under the control panel are painted in RAL 9016 (Traffic white) as standard, but can be painted in any RAL color as an option. The full height wall is available for platform sizes with machine side 1040,1280 and 1480 mm. When ordering a full height wall for platform 900 x 1040 mm, the electrical cabinet must be external.

FOLD DOWN SEAT

In solid birch and with chromed brackets. The seat has to be folded back manually after use. Can be ordered as an option.

Size: 320 x 400 mm

Not available for 900x1040.



FLOOR

Choose between the following options for vinyl, rubber and aluminum floorings.

It is also possible to order the lift without a flooring, which enables you to put in your own flooring. Maximum thickness of an externally selected floor is 3 mm. Note that aluminum flooring is not available for platform size 900 x 1040 mm.



Dark Grey Vinyl
Standard



Light Grey Vinyl
Standard



Aged Oak Vinyl
Standard



Oiled Oak Vinyl
Standard



European Oak Vinyl
Standard



Aluminum
Option



Checker Stud Black Rubber
Option

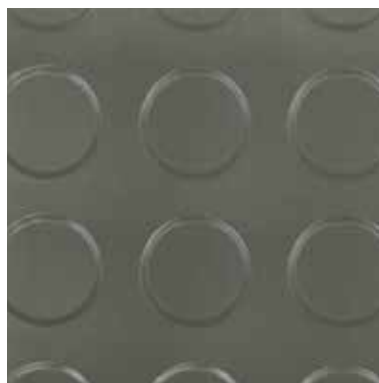

Checker Stud Grey Rubber
Option

CONTROL PANEL

The control panel is delivered with a light box, with an acrylic glass that is lit with LED light.

The destination buttons, emergency stop button, alarm button, autodialer (option), landing indicator (option), max weight and number of persons allowed are located on an aluminum panel. Parts around the light box and aluminum panel are painted in grey, anodic color Natura, that looks like aluminum.

For Aritco PublicLift Access you can choose between two different control panels;

- Control panel - Standard version (standard)
- Control panel - Extra large buttons (option)

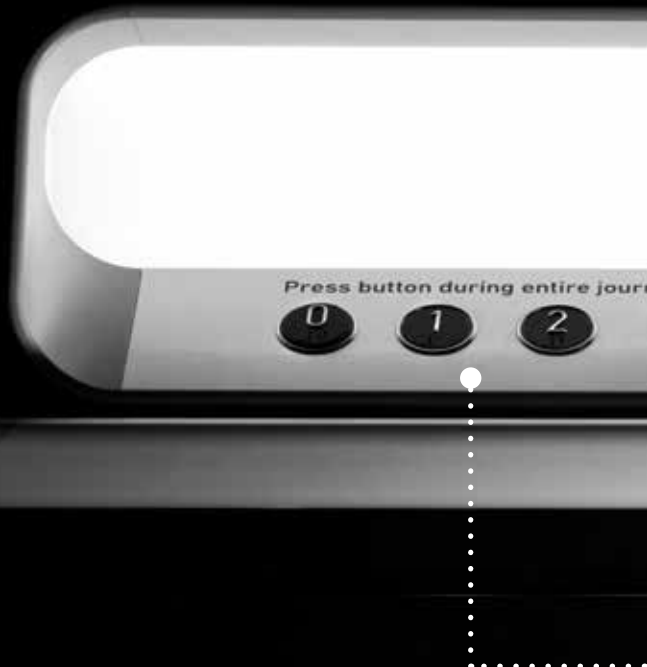

LANDING INDICATOR

A digital display positioned at the control panel. It shows which floor the lift is on at the moment. The indicator can also be fitted with a voice announcer available in Danish, Dutch, English, Finnish, French, German, Norwegian, Polish, Russian and Swedish. Voice: Basement, Ground floor, Floor 1-6.

The landing indicator can also show information from the system.

- Warning if the batteries are low.
- A bell when the alarm button has been pressed.
- Number of starts and total run time since installation or since last reset.
- A weight symbol will appear if the lift is overloaded.
- If connected to the buildings fire alarm a "Fire" symbol will be shown when alarm is activated.

Can be ordered as an option.

ALARM BUTTON

A standard alarm button is always delivered with the lift. When it is pressed a buzzer sounds. This is only a signal to the user that the button is pressed. The alarm button may be connected to an external alarm sounder or an autodialer. The alarm button is standard.

EXTERNAL ALARM SOUNDER

An external alarm sounder mounted outside the lift. It is connected to the alarm button and when the alarm button is pressed the external alarm

sounder will give a loud signal outside the lift to attract attention in case of emergency. Can be ordered as an option.

EMERGENCY STOP BUTTON

A button in "mushroom" type for emergency situations. Light indicates if it is pressed down or not. Is always included as standard.

HANDRAIL

A handrail is mandatory according to EN81-41 and delivered as a standard. Height of handrail is 875 mm from the platform floor. The ends of the handrail are closed and turned to the platform. The handrail is made of aluminum with zinc corners and are painted in RAL 9016 (traffic white) as standard. When platform is ordered in another color than standard the handrail will be painted in grey, Anodic color Natura, that looks like aluminum. It is the same color as is used for the details around the control panel. Both the grey and white handrails will have a glossy surface to protect them from wear and tear and from getting dirty. In the handrail there is an integrated LED light, that gives light on the floor (50 LUX).

GREEN RING - IDENTIFICATION FOR EXIT FLOOR

A green ring, indicating the exit floor can be selected on one of the destination buttons (max one per lift). The green ring is included as standard.





CONTROL PANEL - STANDARD VERSION

Standard control panel for Aritco PublicLift Access is with 32 mm large buttons with text/numbers and braille. Following buttons are available: -2, -1, 0, 1, 2, 3, 4, 5, 6, 0A, 0B, 1A, 1B, 2A, 2B, 3A, 3B, BG, E, G, K, U, B

Destination buttons are according to EN 81-41 for disabled. The location of the buttons is within the limits in the standard, i.e. height between platform

floor and the center line of the buttons is between 900-1100 mm.

The touch plate of the buttons is in aluminum, black anodized (AlMg3 EV6). Text/number embossed. Height of text/number 15 mm. With Braille.

6 buttons/floors possible for all combinations, except for when having landing indicator and key lock on the control panel, then 5 buttons/floors are possible.

KEY SWITCH ON PLATFORM

A key switch placed on control panel. The key switch locks the platform functions and prohibits unauthorized use. One key switch per platform can be provided. The key switch can be serial connected to all destination buttons or the key switch is connected to one destination button.

Two brands to choose from:

- ASSA (Nordic markets only). Aritco only delivers the housing, Aritco does not deliver the locking cylinder.
- Telemecanique

Can be ordered as option.



CONTROL PANEL - EXTRA-LARGE BUTTONS

The optional control panel for Aritco PublicLift Access is with extra-large 50 mm large buttons with text/numbers and braille. With the extra-large buttons you have the possibility to provide enhanced accessibility. Often used in hospitals. Following buttons are available; -2, -1, 0, 1, 2, 3, 4, 5, 6, 0A, 0B, 1A, 1B, 2A, 2B, 3A, 3B, BG, E, G, K, U, B

Destination buttons are according to EN81-70 Annex B for disabled. The location of the buttons is within the limits in the standard, i.e. height between platform floor and the center line of the buttons is between 900-1100 mm.

The touch plate is in stainless steel in black. Text/number embossed. Height of text/number 30,3 mm. With Braille.

6 destination buttons/floors are possible when having a lift with only destination buttons. Due to space limitations on the control panel lifts with a landing indicator or key lock can have only 5 destination buttons/floors. For lifts with both landing indicator and key lock only 4 destination buttons/floors are possible.





DOORS

The landing doors installed at each landing are made of galvanized steel and laminated and toughened glass, 8 mm thick.

All doors are painted in RAL 9016 (Traffic white) but can be painted in any RAL color as an option. The door frame and door blade can be painted in same color or the frame in one color and the blade in another color. For the same lift all doors must be

painted in the same color. A glassed area according to EN81-41 is standard for all doors. Standard is with clear glass (JT0). Optional is to have tinted glass (JT16).

The profiles around the door glass are as standard aluminum. For large glass doors and half height doors they can be painted in the same color as the door blade.

All doors can be left- or right hinged. Doors are always delivered with door frame. It is not possible to order the door or the frame separately.



Large glass door



Half height door



EI60 - Fire & smoke proof door

LARGE GLASS DOOR

Large glass door with one glass window.

Opening widths: 800, 900, 1000 mm

Opening heights: 1800, 1900, 2000, 2100, 2300 mm

The actual height of the door is 40 mm higher since a plate that covers the joint between the door and the frame is mounted on the door.

Glass window (vision): 612x1472 mm (800 mm wide door), 712x1472 mm (900 mm wide door)

Standard: Door blade and door frame in RAL 9016 (Traffic white). Glass window: clear glass (JTO). Aluminum door glass profiles.

Options: Door blade and /or door frame in other RAL color. Glass window: tinted (JT16). Painted door glass profiles.

Door opening width	Door opening height	Available for B-side	Available for A/C-side
800	1800 / 1900 2000 / 2300	1040	900
900	1800 / 1900 2000 / 2100 2300 ²⁾	1280 1480 1580	1000 1100
1000	2000 / 2100 ¹⁾	1280 / 1480 1580	1100

¹⁾ 2100 mm doors are available for 1100 and 1280 mm only.

²⁾ 2300 mm doors are available for 1000 and 1100 mm side. Not for 1280, 1480 or 1580 side.

(mm)

Clear glass

JTO

Tinted glass

JT16



HALF HEIGHT DOOR WITH GLASS

Half height door with one glass window. If you require an open shaft or if the head space is low, the use of a half height door may be a good solution. According to EN81-41 the half height door is only allowed for lifts with a travel height up to 3 meters (within Europe). The half height door can not be combined with EI60 fire & smoke proof doors. Note that when using a half height door 1100-1600 mm the shaft and the half height door will end at the same height. It is not possible to have a higher shaft than the half door.

Opening widths: 800, 900 mm

Opening heights: 1100-1600 mm

Glass window (vision): 612x670 mm (800 mm wide door), 712x670 mm (900 mm wide door)

Standard: Door blade and door frame in RAL 9016 (Traffic white). Glass window: clear glass (JTO). Aluminum door glass profiles.

Options: Door blade and /or door frame in other RAL color. Glass window: tinted (JT16). Painted door glass profiles.

Door opening width	Door opening height	Available for B-side	Available for A/C-side
800	1100 1101-1600 ¹⁾	1040	900
900	1100 1101-1600 ¹⁾	1280 1480	1000 1100

¹⁾ Custom height

(mm)

Note: For platform size 900x1040 mm, the electrical cabinet is placed on top of the mast. The machine side is 200 mm higher than the rest of the shaft.

A half height door can be used in the following cases:

- 1100 mm high half height door: When you have an open shaft and a top height of 1100 mm (even shaft).
- 1101-1600 mm high half height door: When you have a low travel height with a standard door on the bottom floor and a custom height half height door is needed to get an even shaft (see page 18 for details).
When you have a higher travel height, but a standard door on second top floor and a custom height half height door is needed to get an even shaft.

It is not possible to have a lower half height door than the top height of the shaft - this means that you can't have a 1100 mm height door on a lift with shaft height of for example 1400 mm.

Note that it is not possible to have two half height doors on the same lift.

DOORS

TRAVEL HEIGHTS

When using a customised height half door, consider the following criteria regarding travel height. Note that the travel height is depending on if the lift is installed with or without a pit.

For large glass doors:

Door opening height ¹⁾	Travel height when a ramp on first level	Travel height with a pit on first level
1800	490 - 990	440 - 940
1900	590 - 1090	540 - 1040
2000	690 - 1190	640 - 1140
2100	790 - 1290	740 - 1240
2300	990-1490	940-1440

¹⁾ The height of the frame is always 240 mm higher than the door opening height.

(mm)

Example with door opening height 2000 mm.

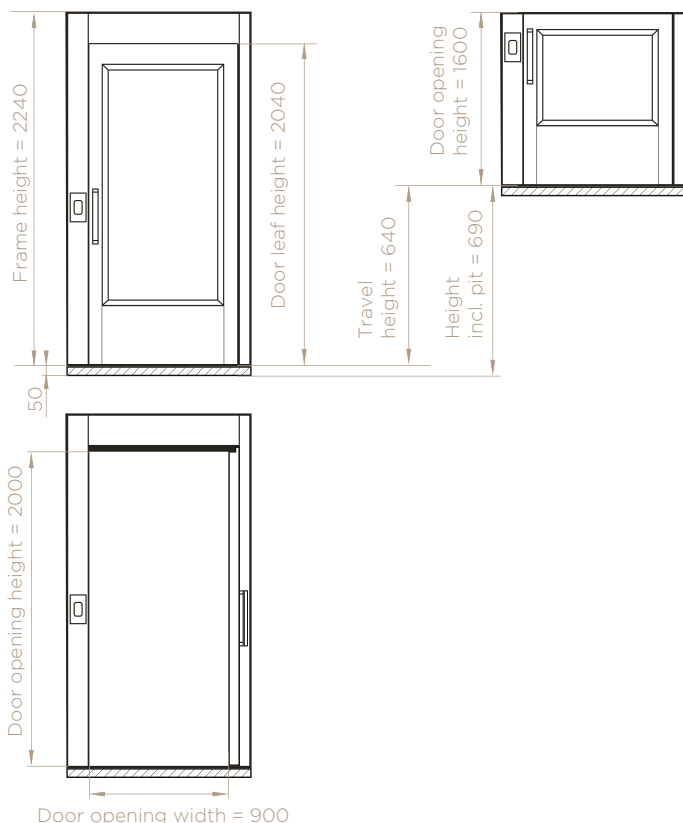

DOOR OPENING HEIGHT

The actual height of the door is 40 mm higher since a plate that covers the joint between the door and the frame is mounted on the door. For door opening height 2000 mm the actual door height is 2040 mm.

DOOR FRAME

A door frame is always delivered with the door. The size of the frame depends on the platform size and the door opening width and height. The height of the frame is always 240 mm higher than the door opening height.

Door opening height	Frame height
1800	2040
1900	2140
2000	2240
2100	2340
2300	2540

A/C -side

Platform side	Frame size
900	1060
1000	1160
1100	1260

B -side

Platform side	Frame size
1040	1060
1280	1300
1480	1500
1580	1600
1980	2000

(mm)

Examples of possible displacement of door on B-side (door opening 900 mm and 1000 mm) :

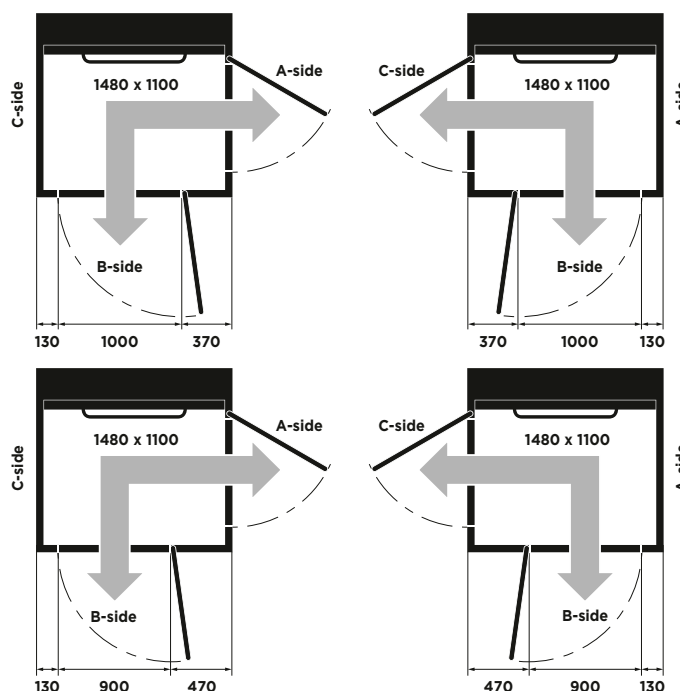

DISPLACEMENT OF DOOR ON B-SIDE

If it is not possible to fit the door on the B-side in the standard location, it is possible to place the door to the left or to the right. Large glass door and half height doors can be displaced. It is not possible to displace EI60 fire & smoke proof doors.

Door opening 900 mm (large glass door and half height door):

Platform size on B-side	Frame size	Standard frame	Displaced to the left	Displaced to the right
1280	1300	200/200	130/270	270/130
1480	1500	300/300	130/470	470/130
1580	1600	350/350	130/570	570/130

Only for large glass door with door opening height 2000 mm. (mm)

Door opening 1000 mm (large glass door):

Platform size on B-side	Frame size	Standard frame	Displaced to the left	Displaced to the right
1480	1500	250/250	130/370	370/130
1580	1600	300/300	130/470	470/130

Only for large glass door with door opening height 2000 mm. (mm)

EI60 - FIRE & SMOKE PROOF DOOR

EI60 - Fire & smoke proof door complies with the lift directive and EN 81-58. As standard the EI60 door is delivered with a frame. As an option a widening panel for the A and C side can be ordered to cover the machine side part. The widening panel is available with or without a hatch to cover the electrical cabinet.

Opening width: 800, 900, 1000 mm

Opening height: 1800, 1900, 2000, 2100 mm

The actual height of the door is 20 mm higher since a plate that covers the joint between the door and the frame is mounted on the door.

Installation: Not in combination with half height door.

Standard: Door blade and door frame in RAL 9016 (Traffic white), Glass window in clear glass (JT0). Aluminum door glass profiles.

Options: Door blade and /or door frame in other RAL color.

Note that the profiles around the glass window are in aluminum and are not painted in the same color as the door.

Door opening width	Door opening height	Available for B-side measure	Available for A/C -side measure
800	1800 / 1900 2000 / 2100	1040	900
900	1800 / 1900 2000 / 2100	1280 / 1480 1580	1000 1100
1000	2000 / 2100	1280 / 1480 1580	1100

(mm)

EI60 - FIRE & SMOKE PROOF DOOR FRAME

A door frame is always delivered with the door. The size of the frame depends on platform size and the door opening width and height. The height of the frame is always 220 mm higher than the door opening height.

Door opening height	Frame height
1900	2120
2000	2220
2100	2320

(mm)

B-side

Platform side	Frame size
1040	1060
1280	1300
1480	1500

(mm)

Note: For B-side 1580 mm and 1980 mm fire doors are not available.

A/C-side

Platform side	Frame size
900	1060
1000	1160
1100	1260

(mm)

WIDENING PANEL FOR A AND C SIDE

As an option a widening panel for the A- and C-side can be ordered to cover the machine side part. The widening panel is available with or without a hatch for the electrical cabinet. The widening panel is available for door opening height 1800, 1900, 2000 and 2100 mm and has the same height as the door frame.

DOOR CONTROL

The door control is either placed on the door frame of each landing door and/or placed away from the lift as an external control.

DOOR CONTROL ON DOOR FRAME

Door control placed on the door frame on the lift. For Aritco PublicLift Access there is always place on the door frame for a door faceplate.

CALL BUTTON

The call button comes with a background lit frame which indicates the status of the lift.

- Green light indicates that the lift is at your floor. Lit only on the floor where the platform is at the moment.
- Red light indicates that the lift is occupied. It is busy and you can't call for it.
- The flashing light indicates that the security circuit is broken, e.g. that the emergency button is pressed, the door is open on another floor for more than one minute, the door is blocked or the safety frame is pressed down. The flashing light can also be activated by a sum alarm, more information is then available in the service memory.

The same type of call button is used when the door control is placed on the door frame, externally or as a radio controlled call button.



DOOR FACEPLATE

The door faceplate can be placed directly on the door frame or externally in an external call station box. The door faceplate is in standard painted in grey, anodic color Natura which has an aluminum look. The door faceplate can hold:

- Call button
- Key switch with Telemecanique / School locking
- Key switch prepared for Assa or EUR / School locking
- Call button and key switch with Telemecanique / School locking
- Call button and key switch prepared for ASSA or EUR / School locking



EXTERNAL DOOR CONTROL - PLACED AWAY FROM LIFT

Door control placed away from the lift in an external call station box connected to the lift via a cable or as a radio controlled call button without any cable.

EXTERNAL CALL STATION BOX

The door faceplate can be placed away from the lift and will then be placed in an external call station box. The color of the external call station box is RAL 9016 (Traffic white). The box can either be mounted exterior on a wall (wall mount) or in the wall so that you only see the door faceplate (flush mounted). The external call station box can be ordered as an option.

The standard length of the cable delivered with the external call station box is 1.5 m, as an option it can be 10 m long.

Size flush mount: 82x150x50 mm

Size wall mount: 95x185x50 mm



KEY SWITCH / SCHOOL LOCKING

Instead of having a normal call button on the door faceplate you can have a key switch. You then need to have the key to be able to call for the lift and to access the lift. Includes school locking function which automatically locks the door 10 seconds after it is closed. Aritco can provide one key switch per door.

Three brands to choose from:

- ASSA (Nordic markets only). Aritco only delivers the housing, Aritco does not deliver the locking cylinder.
- EUR, Aritco only delivers the housing. Aritco does not deliver the locking cylinder.
- Telemecanique



RADIO CONTROLLED CALL BUTTON

The radio controlled button, placed in a white plastic box, gives the customer the freedom to place the call button wherever they would like within 10 meters from the lift. The radio controlled call button runs on batteries and provides remote controlled access to the lift.

The radio controlled call button doesn't indicate the status of the lift.

Can be ordered as an option.



DOOR MACHINERY

The landing doors are always delivered with either a door opener or a door closer.

Depending on the door type you can either have it mounted internally (in the door frame so that you can't see it from the outside) or externally (in a box visible from the outside).

Door opener: Opens and closes the door automatically. Door open time and the opening speed are adjustable.

Door closer: Door is opened manually. The door is closed automatically.

All openers and closers are available for both left and right hinged doors. When having two doors on the same landing, both doors will be opened at the same time when having door openers.

Door type	Internal door closer	External door closer	External door opener	External door opener FAAC
Large glass door Standard	•	•	•	•
Half height glass door	•		•	
EI60 - fire & smoke proof door	•		•	•
Outdoor lifts	•	•	•	•

INTERNAL DOOR CLOSER

Closes the door automatically. It is built into the door frame and is invisible from the outside. Includes function to keep door open until the user manually closes the door. Standard for all doors.

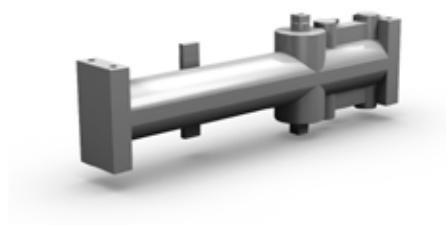

EXTERNAL DOOR CLOSER

Closes the door automatically. Can be ordered as an option.



HOLD OPEN ARM

Keeps the door open until the user manually closes the door. Can be combined with external door closer only. Can be ordered as an option.



EXTERNAL DOOR OPENER

Opens and closes the door automatically after a preset time. Can be ordered as option. Cover and sides painted in RAL 9016 (Traffic white) as standard. If the door blade is painted in another color, the cover will be painted in the same color. The sides will still be in RAL 9016 (Traffic white).



EXTERNAL DOOR OPENER FAAC

Opens and closes the door automatically after a preset time. Suitable for tougher public & commercial environments. For both indoor and outdoor installations. The opener is installed on the door frame which makes it suitable for installations where space is limited and when lift door opens up close to a wall. Smart logic makes it possible to program the speed and force, depending on door type. If an obstacle is detected, the door re-opens immediately. Then it closes, checking, at reduced speed, that the obstacle is no longer present. Cover in aluminum and sides in grey plastic. Can be ordered as option.



DOOR OPTIONS

DOOR HANDLE

Door handles casted in zinc standard painted in grey, anodic Natura, that looks like aluminum. For lifts ordered with door blades in standard color RAL 9016 (Traffic white) it is possible to order the door handles in the same color as an option. Both the grey and white door handles will have a glossy surface to protect them from wear and tear and from getting dirty.



Anodic Natura
(aluminum look)

Traffic white
(RAL 9016)

ARRIVAL GONG

The arrival gong gives an audible signal (ding dong) when the platform arrives at each landing. It is placed in the door frame on each landing. Can be ordered as an option.

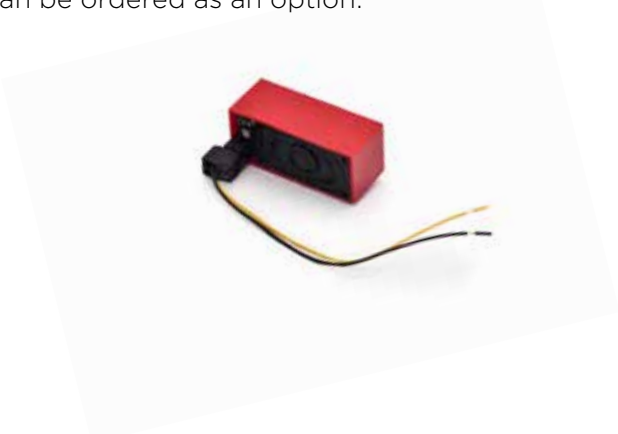

LANDING INDICATOR ON DOOR

Digital display positioned at the door frame. It shows which floor the lift is on at the moment. The landing indicator can also show following system information:

- Warning if the lift batteries are low.
- A bell when the alarm button has been pressed.
- Number of starts and total run time since installation or since last reset.
- A weight symbol will appear if the lift is overloaded.
- If connected to the buildings fire alarm a "Fire" symbol will be shown when alarm is activated.



COVER PLATE

If the door control is placed externally and not on the door frame a cover plate that covers the hole in the door frame is delivered with the lift. The cover plate is always delivered with the lift in the same color as the door frame. Standard color is RAL 9016 (Traffic white).

RAMP

If the lift is installed without a pit a ramp is mandatory according to EN81.41. The ramp is made of galvanized steel covered with corrugated aluminum to prevent slipping. The vertical rise of the ramp is less than 1:4. The ramp can be ordered as an option for lifts installed without a pit. Ramp dimensions: Height 50 mm, width 420 mm, length 1160 mm.

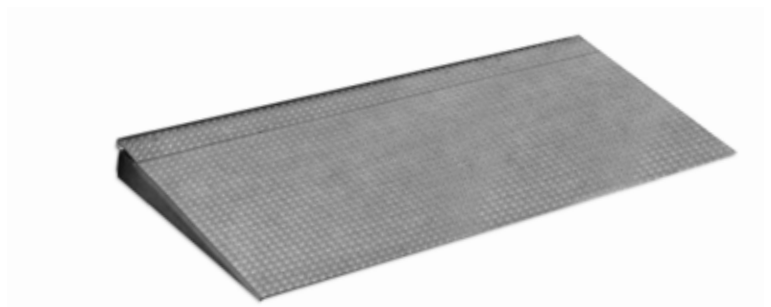

LIFT WALLS

The lift is always delivered with a self supporting shaft.

The lift always comes with cladding panels on the inside of the shaft on the machine side. If the lift is not installed against a wall, machine side cladding can be added on the outside of the lift to cover the machine side. For all sides except for the machine side you can choose to have shaft panels in steel or glass. The top height of the shaft for Aritco PublicLift Access is not fixed. When having a standard door on the top floor, the minimum top height depends on the door opening height and the frame height. For a door opening height of 2000 mm the standard frame height is 2 240 mm, which is the lowest top height. Higher top height can be ordered. Maximum top height is 4000 mm.

CLADDING PANELS

Cladding panels covering the inside of the machine side are delivered as standard. As standard the panels are in RAL 9016 (Traffic white), but if the shaft is painted in another color the panels will be painted in the same color.

MACHINE SIDE CLADDING

The machine side cladding in steel covers the backside of the machine side if the lift is not installed against a wall. The machine side cladding can be ordered as an option and can run from bottom to top height. It can also be ordered partly if the lift is partly mounted to a wall. The cladding is painted in same color as shaft panels.

Size: Travel height plus top height.

GLASS

As an option glass panels with laminated and toughened glass can be ordered. Standard is clear glass (JT0). Option with tinted (JT16). See page 17. The glass panels are 8 or 10 mm thick depending on the size of the glass. Glasses which are higher than 1000 mm are always 10 mm. The glasses are fitted in aluminum profiles. These profiles are in aluminum as standard, but can be painted in a RAL color as an option. For a shaft painted in the RAL 9016 (Traffic white) the profiles can be painted in the same color. For a shaft painted in another RAL color the profiles are as standard aluminum. As an option the profiles can be painted in the same RAL color. Note that this has to be ordered separately.

INNER CEILING

For a closed shaft you can add an inner ceiling as an option. The inner ceiling is painted in RAL 9016 (Traffic white) as standard, but will be painted in the same color as the shaft if the shaft is painted in another color. Choose between the following options, which complies with LUX regulations:

- Built-in LED light or surface-mounted LED light fitting.
- Surface-mounted LED light fitting (not for 900x1040 mm platform)

SHAFT PANELS

Standard is 25 mm thick shaft panels with EPS (polystyrene) core and steel plates. The panels are painted in RAL 9016 (Traffic white) as standard. If the shaft is painted in another color the shaft panels will be painted in the same color. The height of the shaft panel is 575 mm. As an option the shaft panels can be ordered with a core of rockwool instead of EPS.

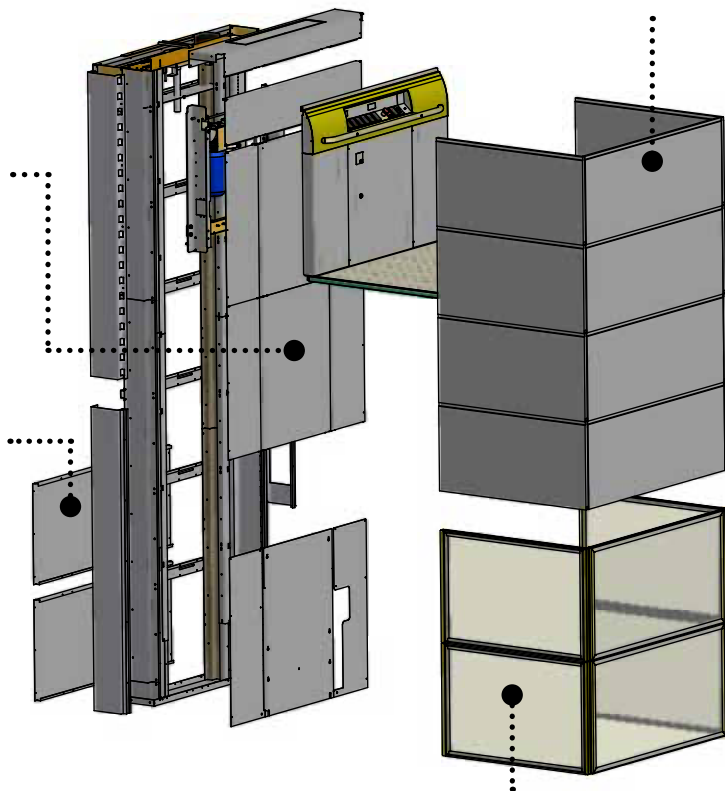

Shaft panels / glass with aluminum profile:

Height (mm)	Clear glass (JT0)	Tinted glass (JT16)
736	•	•
1472	•	•
2208	•	•
Customized ¹⁾	•	•

¹⁾ Additional cost per mm. Maximum height per glass panel is 2200 mm

LIFT WALL OPTIONS

MAST

Aritco PublicLift
Access is always
delivered in parts.

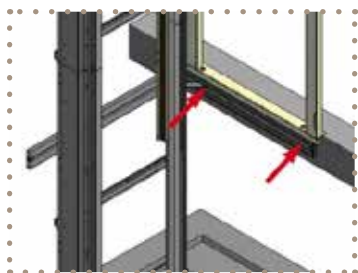
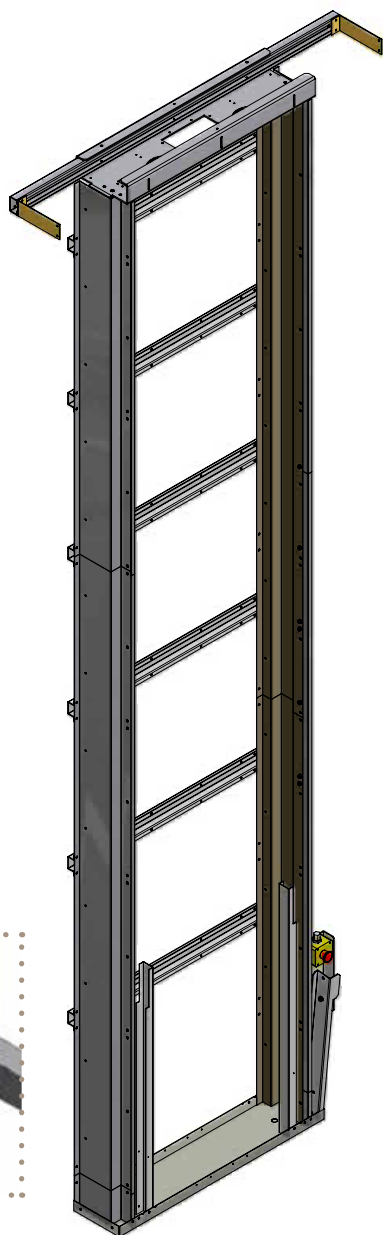

SHAFT SUPPORT BRACKET / L-BRACKET

Installed to stabilize the shaft when it is not mounted against a wall. One shaft support bracket shall be used per floor, except the bottom floor. The shaft support bracket/L-bracket is fixed to the lift on the machine side and in the building on A/C-side (under door). Not possible to fix on B-side.

The shaft support bracket /L-bracket is painted in RAL 9016 (Traffic white) as standard. If the shaft is painted in another color the shaft support bracket is painted in the same color.

The shaft support bracket / L-bracket is available for platform sizes 1040, 1280, 1480, 1580 and 1980 mm.

ELECTRICAL CABINET

The standard position of the electrical cabinet is in the shaft, at the upper floor where the landing door is located. If the standard position of the electrical cabinet proves difficult Aritco offer the option to move it to another landing or to place it externally in a lockable casing. For platform size 900x1040 mm the electrical cabinet is mounted behind the platform panel in the top of the shaft. When ordering a full height wall for platform 900x1040 mm, the electrical cabinet must be external.

Size of standard electrical cabinet (placed in shaft): 180 x 880 mm. Size of external electrical cabinet (placed in an external box): Height 500 mm, depth: 160 mm, width: 400 mm.



EXTERNAL SERVICE PANEL

A service panel is always placed in the electrical cabinet. It is used to run tests etc., and for emergency running the lift. An external service panel is available for mounting outside the lift as an option. In this case a wire connects it with the service panel in the electrical cabinet.

For platform size 900 x 1040 the electrical cabinet and the standard service panel is mounted in the top part of the shaft and can't be reached from outside. Therefore it is connected to an external service panel (wall mount) which is mounted in a faceplate box. The external service panel must be activated with a 3 edge key before it can be used. Size: 95 x 185 mm



EXTRA ANTI-RUST PROTECTION

In order to protect the lift when exposed to humid environments, e.g. when sea transport or when the packed lift is exposed to humid conditions during transport or at the installation site, the lift is delivered with guide rails in corrosion class C5. Can be ordered as an option.

COMMUNICATION

Two way communication is mandatory according to EN81-41. Choose from one of the following options or install your own phone.



Press button during entire journey



PHONE

The telephone works as a standard telephone but is intended for emergency calls. The phone is mounted on the platform panel. Equipped with redial memory, mute button and a lamp indicator for on/off. Can be equipped with a GSM module. Aritco does not supply SIM card.



AUTODIALER

Equipment for emergency calls. Integrated on the control panel. Dials automatically when the alarm button is pressed. When unanswered after a pre-defined time, the call is automatically forwarded to the next number.

The autodialer can be equipped with a GSM module (only 2G). Aritco does not supply SIM card.

DRIVE SYSTEM

BATTERY GUARD

The battery guard ensures that the batteries are not damaged and that there is enough power so that you can run the lift in the case where the power to the lift is cut. It ensures that the lift is turned off (all power consumers are turned off) when the voltage of the batteries reaches below 22 V. This means that even if the power on site is turned off the batteries in the lift will not be discharged and you can still run the lift. The battery guard can be ordered as an option.

PHASE SEQUENCE RELAY

Extra protection to secure that the lift does not run in the wrong direction when the phases are connected incorrectly.

Option introduced for 3-phase lifts.

SOFT START

It provides a smoother start when pressing a destination button. For Aritco PublicLift Access 3-phase lifts, soft start can be ordered as an option. It is not available for 1-phase lifts, as they come with a frequency control as standard which includes both soft start and stop. For 500 kg lifts soft start is included as standard.

BATTERY OPERATED EMERGENCY LOWERING

All Aritco lifts have battery operated emergency lowering as standard. You can lower yourself from inside the lift and get out by yourself when there is a power failure. Possible to run the lift to nearest level from the platform (possible to go down) - Executed when pressing a platform button. Can also be run externally from the call button (hold to run) or service box.



POWER SUPPLY

For Aritco PublicLift Access you have the following options:

3-phase 400V 5.2 A / 16 A slow

- Standard for all lifts (50 Hz)
- Frequency 50 or 60 Hz
- Frequency converter, with built-in soft start and stop (option).

1-phase 230V 16 A / 16 A slow

- Option when building doesn't support 400V 3-phase
- Frequency converter, with built-in soft start and stop
- Frequency 50 or 60 Hz

3-phase 230V 9 A / 16 A slow

- Option
- Note that this is rarely used except for example in Norway and Saudi Arabia
- Frequency 50 or 60 Hz

LUBRICATION

The screw must be oiled at regular intervals.

Manual Lubrication: A brush fixed to the platform oils the screw when using the lift (a tray with lubrication oil in the bottom of the shaft). Standard for Aritco PublicLift Access.

Automatic Lubrication: Oils the driving screw at regulated time intervals even if the lift is not in use. The lubrication frequency is adjustable. Option for Aritco PublicLift Access. Standard for lifts with a travel height of over 8000 mm. Recommended for lifts that are seldom used or that are not used regularly to travel from ground to top floor.



OUTDOOR VERSION

Aritco PublicLift Access Outdoor lift is designed for outdoor use. All outdoor lifts are delivered with guide rails in corrosion class C5.

The outdoor version consists of different options that enable an outdoor installation. Depending on the installation environment different options must be added and the installation conditions that are specified must be followed.

VENTILATION FANS

Ventilation fans mounted in top of the shaft. Two axial fans 230 V, 12 W. The fans are connected to an external power socket, 230 V. The fans are mandatory for outdoor lifts.



ROOF

Roof for outdoor version. If the lift is not installed in an external shaft an outer roof must be used. One roof corner is left open for water outlet. The roof is made of galvanized steel and painted in RAL 9016 (Traffic white) as standard. An inner ceiling with light must be ordered for outdoor lifts when ordering a roof.

DOOR CANOPY

A sloping roof placed above the landing doors to protect them from rain and snow etc. The door canopy is made of galvanized steel and painted in RAL 9016 (Traffic white) as standard. Width: 1160 mm, Slope angle: 23°

HEATER

A heater placed in the bottom of the shaft is recommended for cold climates. Can be ordered as an option. The heater of 2000 W must be connected to an external power socket. Note that for colder climates than -5° the lift must be installed in an external heated shaft.



CONDITIONS FOR INSTALLATION:

Environment temperature max + 40° down to -5°C. If the lift is going to be installed in a colder climate than -5°C, an externally insulated and heated shaft must be built around the lift.

Windload up to 25 m/s. For higher wind loads than 10m/s Aritco offers an option with a glued shaft that can handle wind loads up to 25m/s (Eurocode 1991-1-4:2005). For higher wind loads the lift must be installed in an external building/shaft.

Snow load max 2kN/m². Snow load zone according to EN 1991-1-3. For higher snow loads an external shaft / roof must be installed.

Installation above ground level and with a drained pit. The lift must be installed above ground level and water should be directed away from the lift. The lift pit must be drained and the pit shall also be protected from freezing. The lift is not water tight and water can leak into the lift via landing doors or shaft.

Installation is not recommended in salt or chlorine enhanced environment. For example the lift must not be installed close to sea or close to a swimming pool.

Installation entirely outdoor. The lift must be installed entirely outdoor, i.e. with all landing doors towards the outside. The lift must not be installed with landing doors that go into the building, since the lift can be subjected to downdraughts with condensation problems as a consequence.

Included in standard when ordering an outdoor lift:

- Guide rails in corrosion class C5
- Electrical cabinet cover sealed
- Drive screw sprayed with oil
- A special oil, aimed for outdoor usage must be used (low temperature grade)
- To avoid water leakage, all joints on top roof are to be sealed after installation.
- Ventilation fan in top of shaft, with upper panel with fan holes and lower panel with ventilation holes are included and mandatory for all outdoor lifts.
- Call buttons protected against water, resistant to weather and condensation
- Fixing elements better protected against rust (zink nickel)
- Sealing of doors: A brush stripe for doors that reduces the dirt (and in some extent water) to come into the lift.
- All painted parts have corrosion class C3.

Options to be ordered depending on installation:

- If the lift is installed outdoor and rain can reach

the machine side, a machine side cladding must be used.

- If the lift is not installed in an external shaft an outer roof must be used. Inner ceiling with light (LED) – must be ordered for outdoor lifts when ordering a roof.
- Heater installed in bottom of the shaft, with bottom panel with ventilation holes – option recommended for cold climates.
- Seal of machine side cladding / outdoor roof with a tape/strip.
- If the lift is installed outdoor and there is no roof over the doors, door canopies must be installed over the doors. Option recommended for outdoor lifts.

Aritco reserves the right to deny warranty claims if the lift is not installed in the right environment and if necessary equipment is not used.

LIMITATIONS FOR OUTDOOR LIFTS:

Limitations for wind load up to 10m/s:

- Maximum travel height: 10m
- Shaft panels in EPS only (Rock wool not available) or glass shaft panels.
- Possible to fix lift with L-bracket (specially developed for outdoor usage).

Additional limitations for wind load up to 25m/s:

- Shaft only with shaft panels in EPS. Glass shaft panels not available. Shaft is glued.
- Lift must be fixed against a wall. Fixing with L-brackets is not possible.

Please note that the following are not possible for outdoor lifts:

- Large glass door with height 1800 mm
- Half height doors – all sizes
- Displacement of door on B-side
- Double hinged glass doors - all sizes

NOTE:

- Only available for platform size 1100x1480 mm
- Max travel height 10 m
- Available in over 200 RAL colors from the K7 classic chart
- EPS shaft panels
- Wind loads up to 10 m/s: glass shaft possible
- Wind loads up to 25 m/s: glass shaft not possible

ARITCO PUBLICLIFT ACCESS GOODS VERSION

Aritco PublicLift Access goods version is a version of the Aritco PublicLift Access lift that is intended for both persons and goods.

A risk assessment has been conducted to assess the additional risk that will come when using the platform for persons as well as for goods (Lighter goods transport max 500 kg). Measures to reduce these risks have been taken and they are now implemented for Aritco PublicLift Access goods version.

Aritco PublicLift Access goods version has its own certificate, which is available on Aritco Cloud. Aritco PublicLift Access goods version is available for all platform sizes.



The following is included when ordering an Aritco PublicLift Access goods version:

- Platform with safety edge painted in yellow (RAL 1018).
- Platform with security bar mounted behind the platform faceplate painted in yellow (RAL 1018). Valid when having a half height wall.
- Loading information label - warning sign placed on the platform panel.
- User manual is updated with the Aritco PublicLift Access goods version option and it informs the user of where to place the goods and what size of goods that can be transported with the lift.
- Certificate for persons and goods.

ALUMINUM FLOOR

For Aritco PublicLift Access goods version it is recommended to use the aluminum floor for tougher public & commercial environments and when oil, grease or fat is used.

LOADING INFORMATION LABEL

A loading information label is placed on the platform with pictograms warning for the following:

- Do not load any goods on or outside the yellow border of the platform (safety edges). Prevents the goods to get in contact with the lift walls and get stuck between shaft wall and platform.
- Do not load any goods that are higher than 2 m on the platform. The minimum requirement for free space on top floor is 2 m, the goods will then always have free space upwards.

More information in Aritco PublicLift Access goods version User manual.

Safety bar in RAL 1018

Safety edge in RAL 1018



STEEL KERB

For extra protection of the platform and the shaft walls a steel kerb can be ordered as an option for Aritco PublicLift Access goods version. The steel kerb is a 90 mm high steel frame placed on all sides of the platform, except for door sides. It is recommended when using the lift also for goods. The safety edge will be specially made to fit the steel kerb.

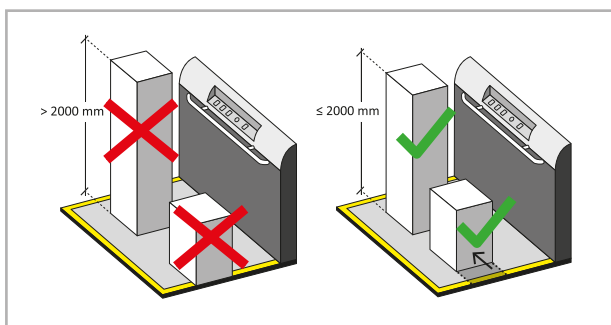

FIXING THE LIFT

Fixing the lift to the walls of the building.

Details regarding the forces are available in the installation manual for Aritco PublicLift Access. Make sure that the entire installation is made in an indoor environment.

Reaction forces from the lift to the building:

Maximum force as a function of the lift's travel. The force is distributed to the floor through the mast bottom within the area "A" and to the shaft bottom within the area "B".

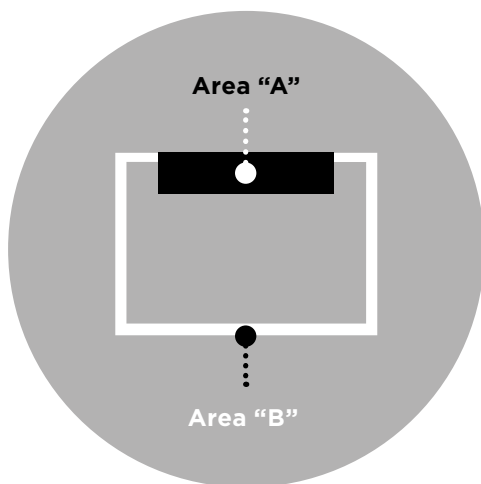

Force on fixing to support frame (mast) to wall:

- $c - c$ = distance (height) from the floor to the highest fixing into the wall.
- The maximum distance between two fixings or lower floor and the lowest fixing is 4,0m. For outdoor lifts maximum distance is 3 m.
- The minimum distance between lower floor and the highest fixing is 2,0 m.
- $c - t$ = distance from the top of the mast to the highest fixing into the wall.
- The maximum distance between the top of the mast and highest fixing is 1,2 m

For exact details for installation see site preparation manual.

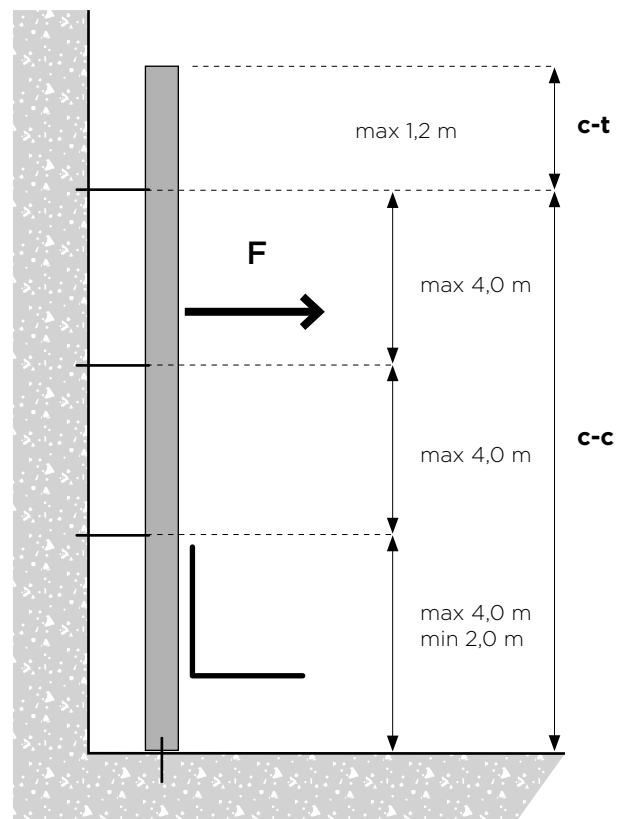

EUROPEAN STANDARDS AND SAFETY

Aritco PublicLift Access comply with the Machine Directive 2006/42/EC, by following the harmonized standard EN 81-41. The lifts are also compliant with the Electromagnetic compatibility (EMC) – and Low voltage directive. The lifts are type approved and CE marked. EI60 – Fire & smoke proof door complies with the lift directive and EN 81-58. A certificate for respective lift is available on Aritco Cloud.

RECOMMENDED SALES ARGUMENTS

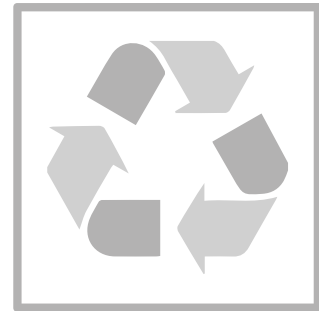
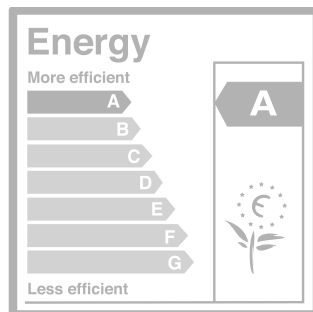

EASY INSTALLATION

Means that the lift is both easy and fast to install. A normal installation only takes two days.

MINIMUM BUILDERS WORK AND SMALL FOOTPRINT

The lift can be installed without a pit, with a ramp (or with a 50 mm pit without ramp). All parts are included in the shaft - no extra machine room or head room needed.

LOW ENERGY CONSUMPTION

Minimum stand-by power consumption 15 W – not more than a computer or a TV. Energy class A as per VDI 4707.

ENVIRONMENTAL PRODUCT DECLARATION

Aritco is the first lift manufacturer with an Environmental Product Declaration. More than 95% of the parts are recyclable.

LOW OPERATION AND MAINTENANCE COST

Lowest on the market.

NO HYDRAULICS, WHICH MEAN NO LEAKAGE OR SMELL

No additional space needed for hydraulic unit.

ROBUST SHAFT

25 mm shaft panels. Robust and resistant to damage. Good noise and acoustical isolation.

SMARTSAFETY SYSTEM

Lift is designed with reliability and safety in focus; to meet all kinds of situations that can occur in public & commercial spaces, as well as to prevent accidents. All these safety features are included in the SmartSafety System. The lift contributes and helps you to create a public space that is safe and accessible for anyone ;

- **Screw and nut drive system:** The self-sustaining concept, i.e. the friction between screw and nut will prevent the lift from falling down. No additional brake system is needed.
- **Power failure operation:** If there is a power failure, you can always get out of the lift by yourself with battery operated emergency lowering. Use the platform buttons and the lift will take you to the closest lower floor and you can open the door and get out by yourself.
- **Emergency calls and emergency operation:** If you are trapped in the lift you can make emergency calls from a phone. It is also possible to lower the lift and get out of the lift
- **Safety edges:** Safety edges around the platform and the platform wall will prevent something to get trapped between the moving platform and the shaft/walls.
- **Locking of lift:** Key switch lock on the platform or the call station that prohibits unauthorized use of the lift.

DRAWINGS

Platform 900 × 1040

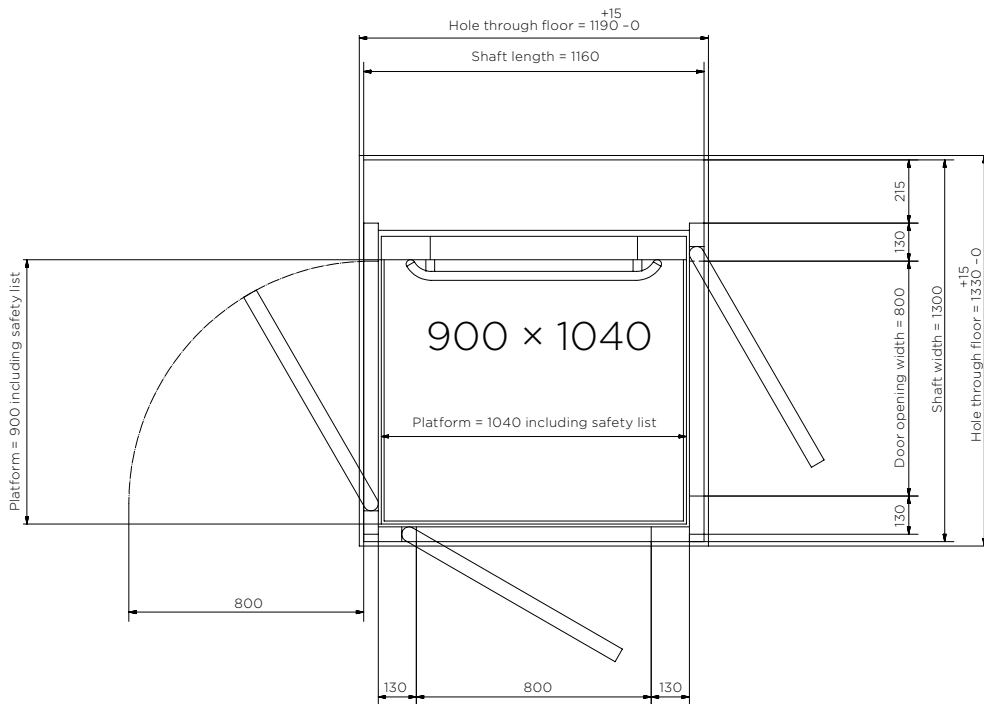
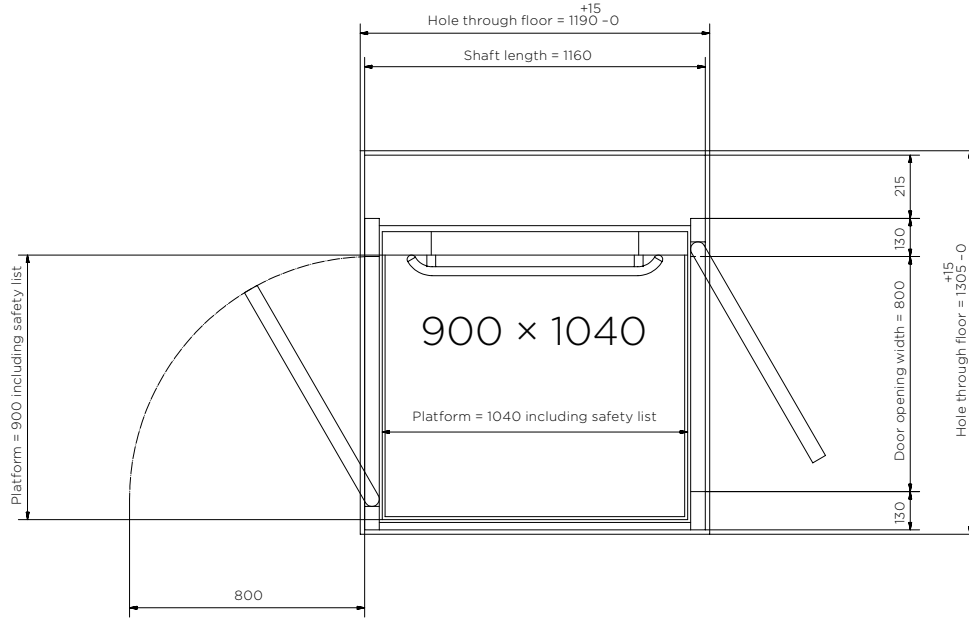

Platform 900 × 1280

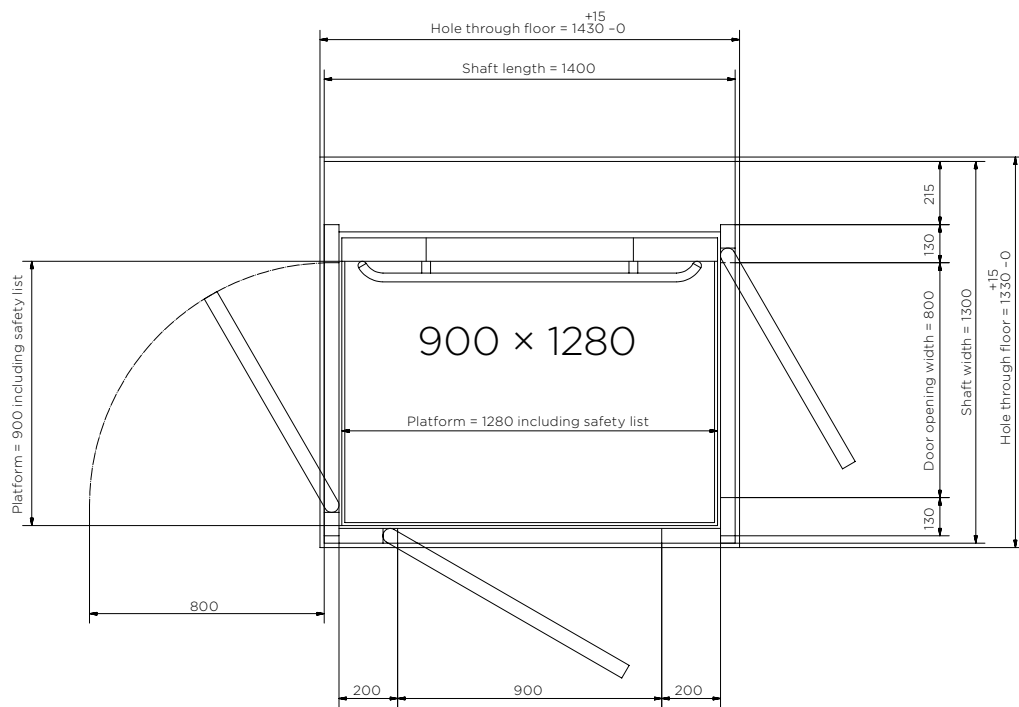
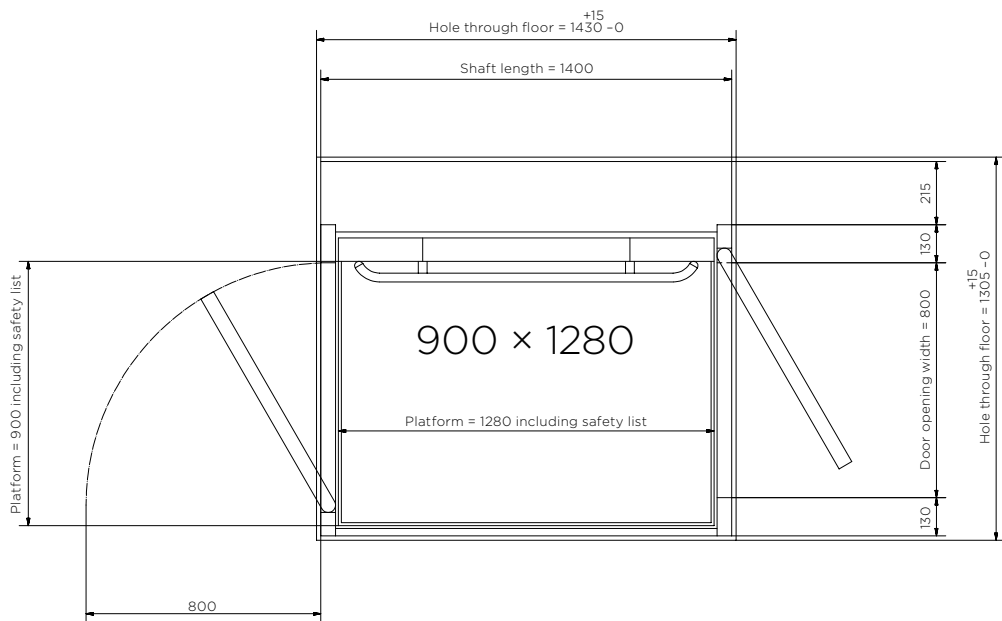

DRAWING

Platform 900 × 1480

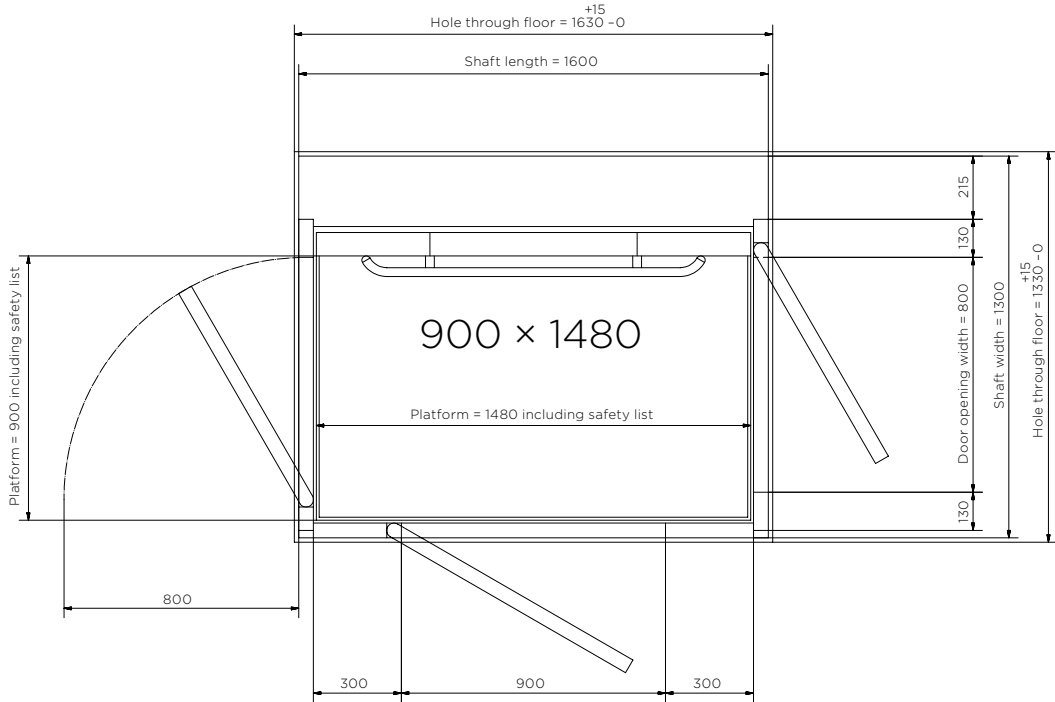
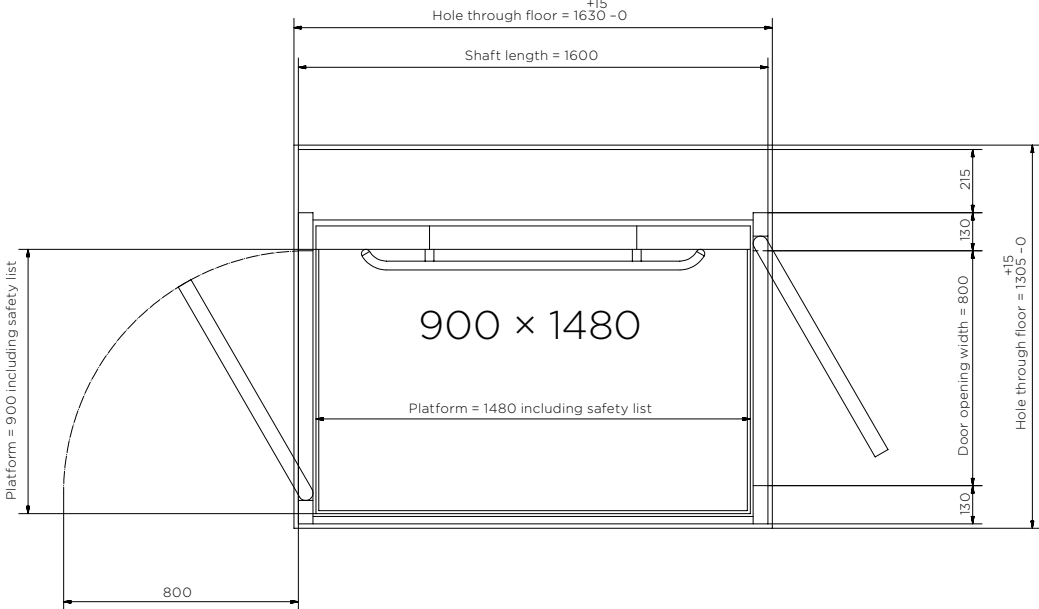

Platform 1000 × 1280

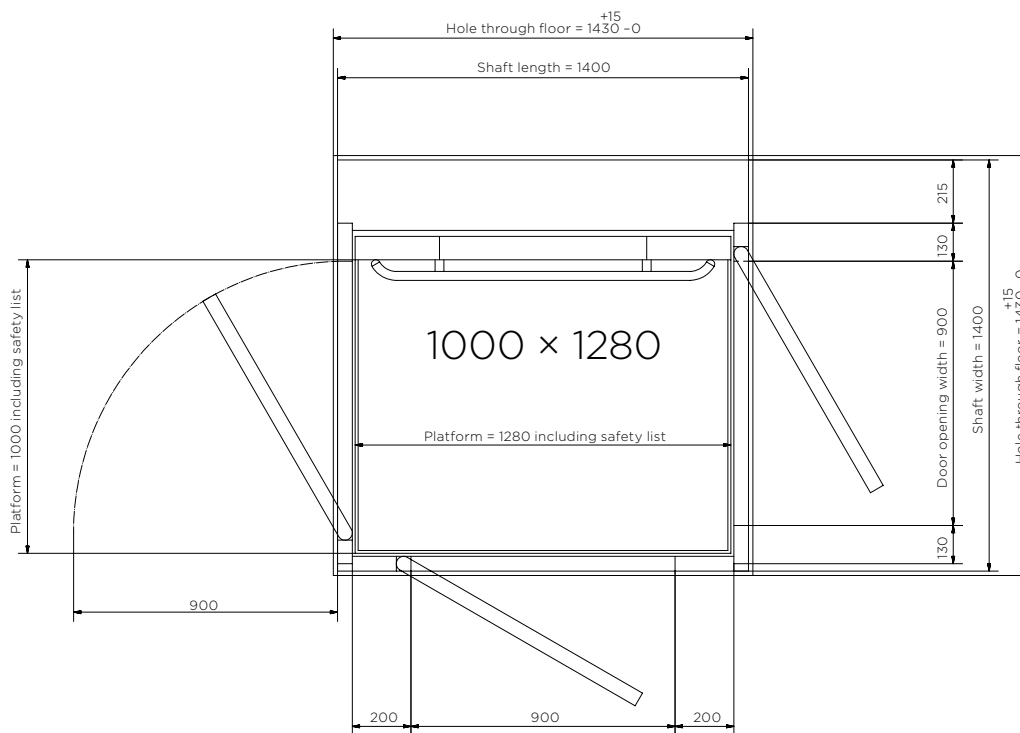
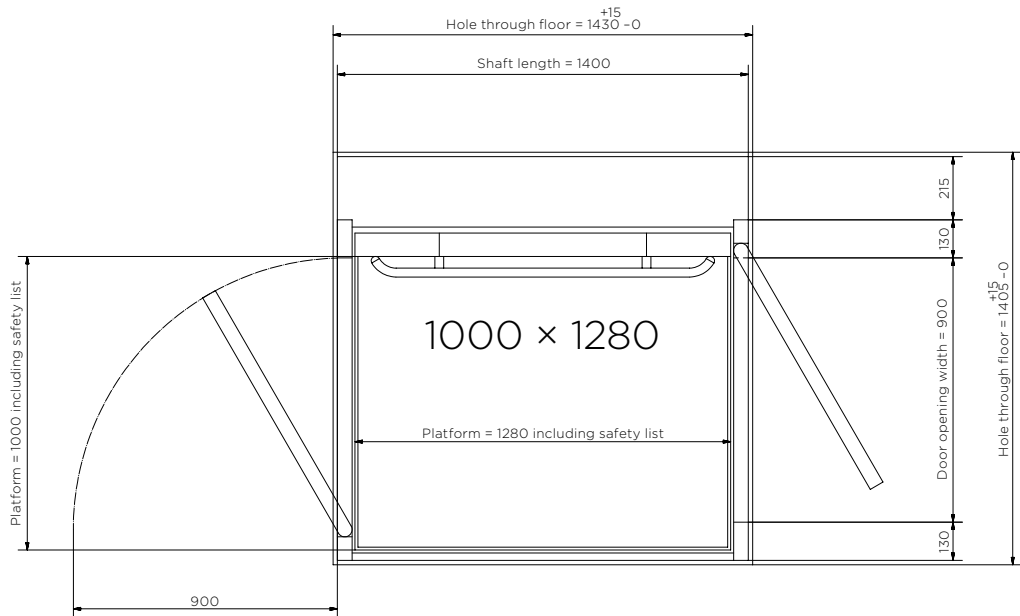

Platform 1000 × 1480

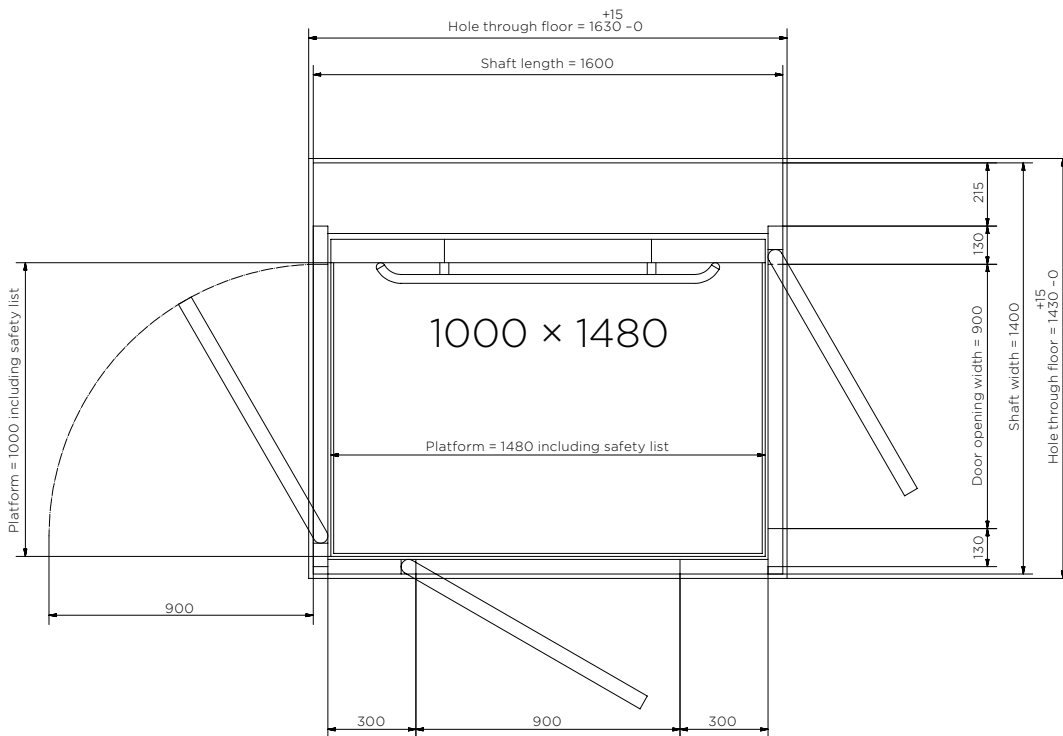
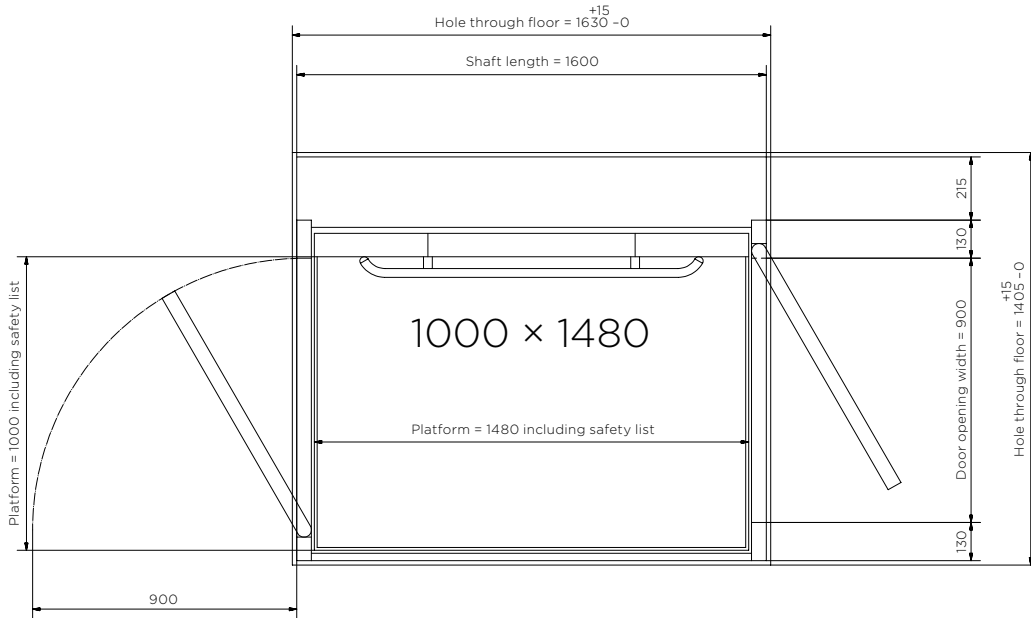

Platform 1000 × 1980

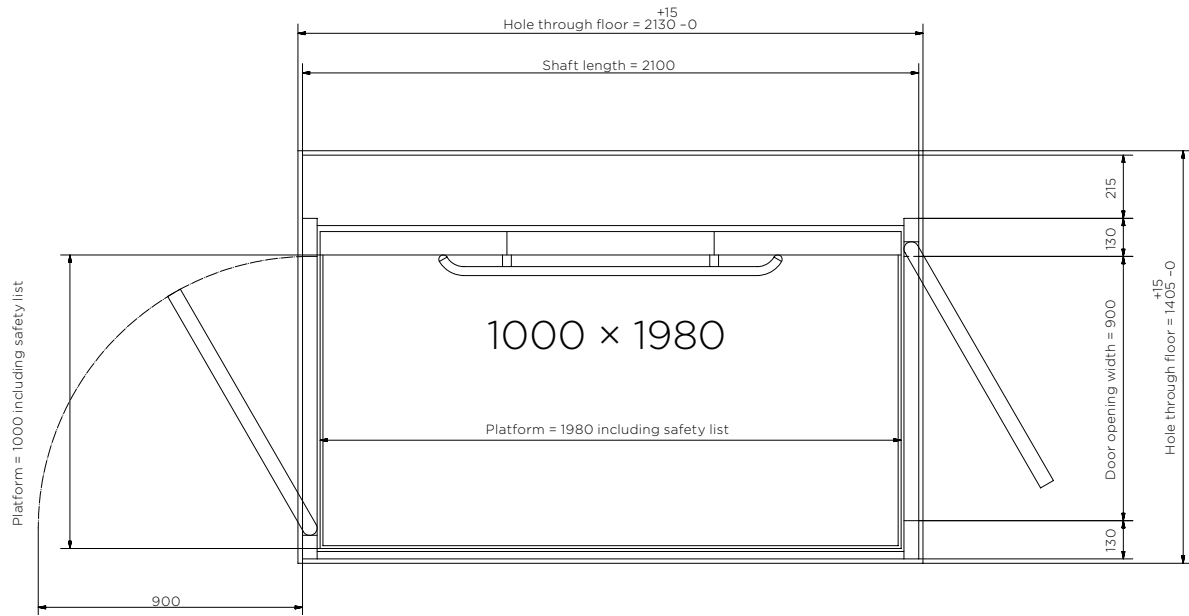

Platform 1100 × 1480

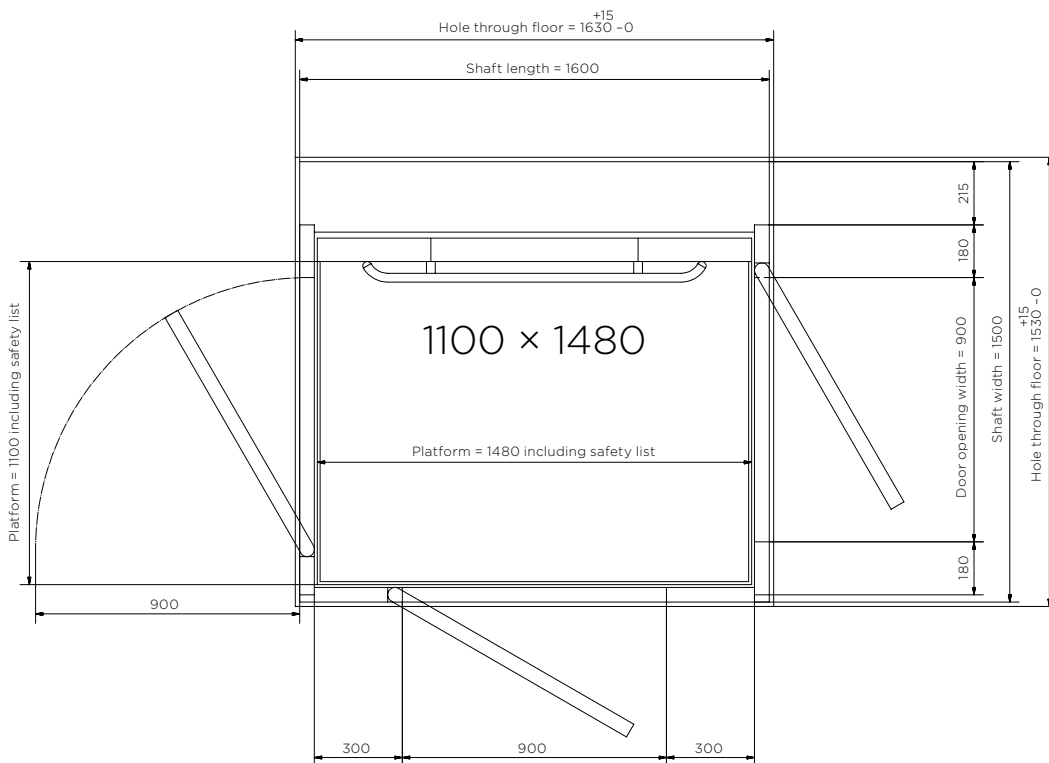
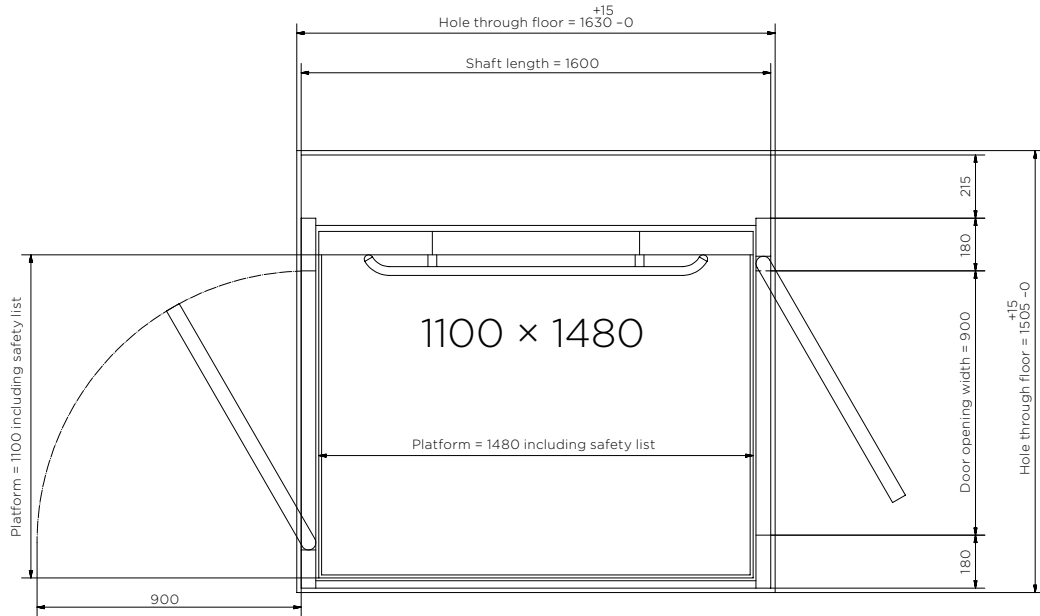

Platform 1100 × 1580

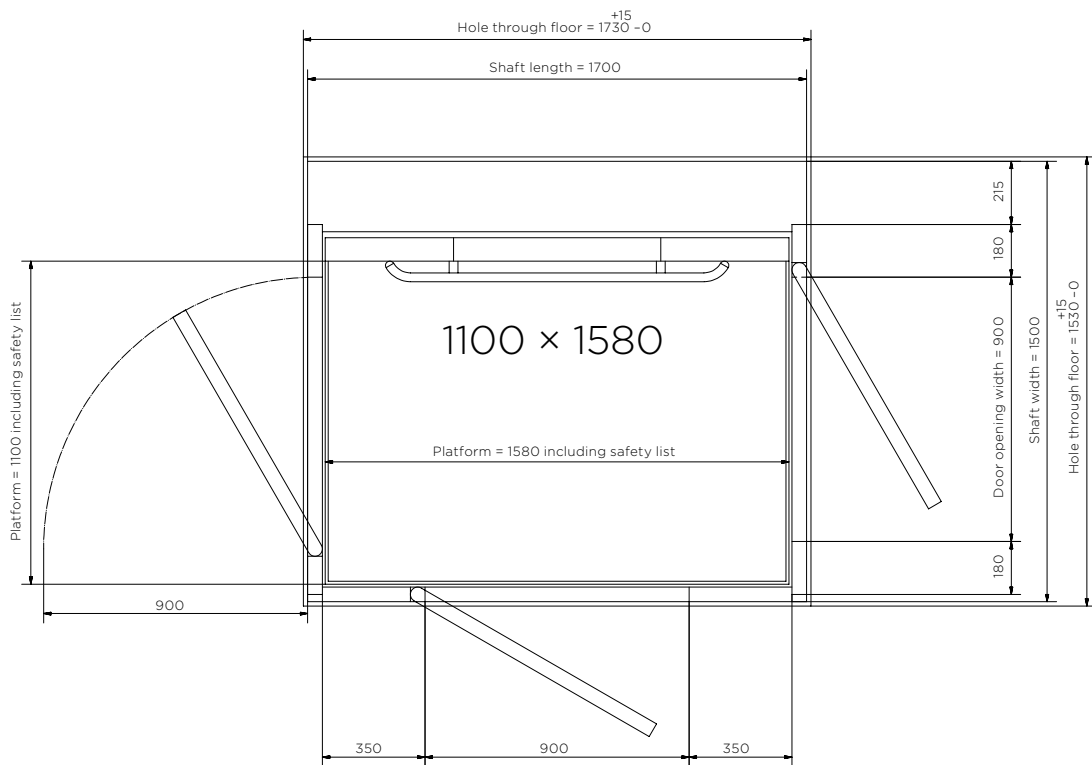
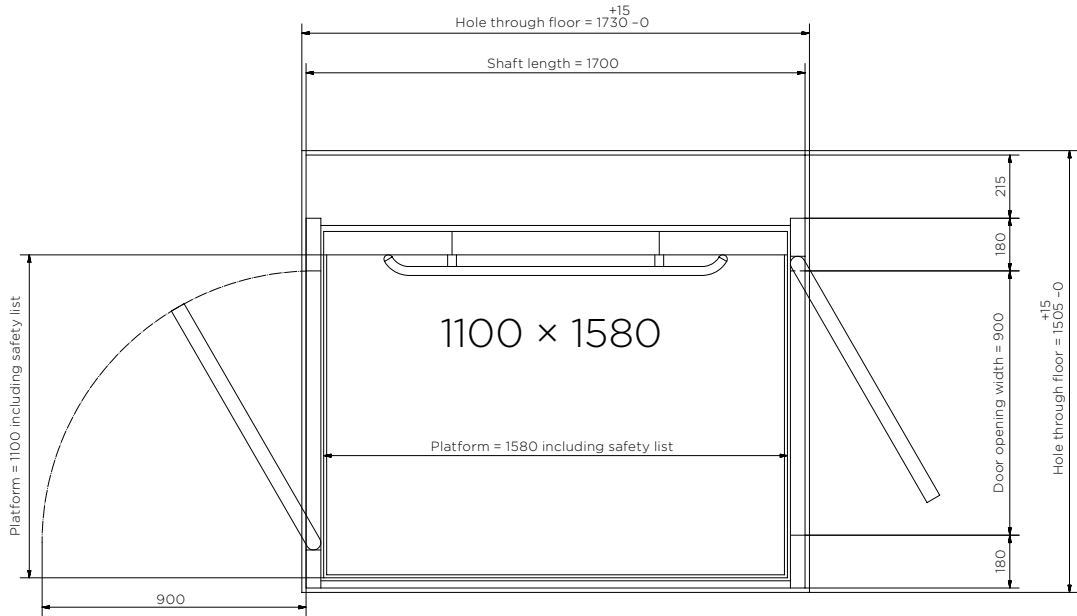

Aritco is a worldleading manufacturer
of platform lifts and home lifts. Read
more at **aritco.com**

Follow Us!

